



*Introducing*

**SP125**

*Anniversary Edition*



*Thank you  
India*



# Built to Celebrate Styled to Lead

The SP125 Anniversary Edition celebrates those who lead with style and confidence. Its striking graphics and refined Pyrite Brown Metallic alloy wheels turn heads on every road.

Every detail is designed to make an impression, crafted for riders who believe progress is as much about presence as it is about motion.

It's the SP125—now in a limited-edition look that stands apart.



# Style that moves with the Time



## ANNIVERSARY SPECIAL GRAPHICS

The SP125 Anniversary Edition steps up with exclusive graphics. Designed to give you a standout look; this special edition celebrates a sense of style for the rider who rides with pride.

## 25 YEARS ANNIVERSARY LOGO ON FUEL TANK

A symbol of Honda legacy and celebration, etched right where it belongs, on a stylishly sculpted tank that reflects pride with every ride



## COLORED SPORTY SPLIT ALLOY WHEELS

Finished in striking Pyrite Brown Metallic, the coloured sporty split alloy wheels, along with the matching brake panel, add a premium edge that instantly sets the SP125 Anniversary Edition apart.





## AGGRESSIVE TANK DESIGN

A definite head-turner, the aggressive fuel tank adds to the dynamic personality of the SP125 Anniversary edition.

## SHARP LED DC HEADLAMP

A sure-shot style statement, the LED headlamp offers consistent illumination, no matter the conditions.



## REAR STANCE WITH SIGNATURE TAIL LAMP

The sculpted rear design seamlessly integrates the signature tail lamp with the body enhancing the design statement.



## PREMIUM CHROME MUFFLER COVER

The stylish chrome muffler enhances the sporty looks.



# Technology that Powers progress



## TFT METER

Honda's class-leading TFT Meter that features an automatic dimming mode, enhancing visibility for seamless and power-packed ride, day and night. Always stay updated with the TFT meter which displays Live Mileage Indicator, Range, Average Mileage, Periodic Maintenance, Gear Position Indicator & Eco Indicator.



LIVE  
MILEAGE  
INDICATOR



RANGE



AVERAGE  
MILEAGE

## Honda RoadSync App\*

- ◆ Manage messages via voice commands
- ◆ Real-time weather updates
- ◆ Turn-by-turn navigation
- ◆ Control music at your fingertips
- ◆ Manage calls directly



## IDLING STOP SYSTEM

Be advanced with the new Idling Stop System that automatically switches off the engine during brief stops, boosting fuel efficiency and making heavy traffic a smooth ride.



\*Creative visualisation applied . Image shown is only for depiction purposes.



## eSP TECHNOLOGY

Honda's Enhanced Smart Power (eSP) technology optimizes performance and mileage by minimizing friction. The ACG starter, seamlessly integrated with eSP, ensures ultra-silent starts, delivering a smoother and smarter riding experience.

## SILENT START WITH ACG

Honda's unique ACG starter motor removes gear meshing noise and helps start the engine without a jolt.

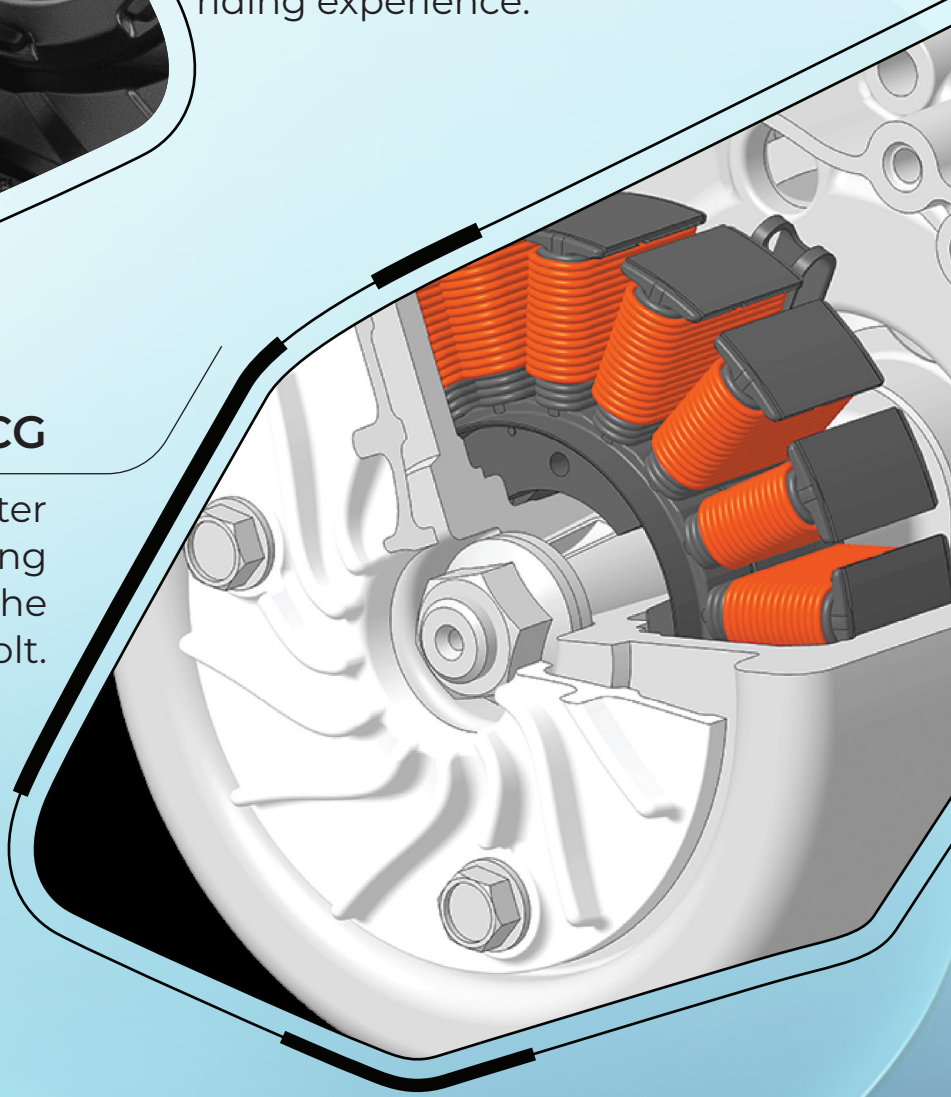

## PGM-FI 125cc ENGINE

The intelligent engine delivers powerful performance while ensuring a cleaner, greener ride.

## FRICITION REDUCTION TECHNOLOGIES

The piston cooling jet reduces friction and maintains optimum engine temperature. The offset cylinder and rocker roller arm further reduces the frictional losses in the engine.



# Comfort that Keeps up

## Universal 15W USB-C PORT

Enjoy your ride. It provides quick charging to your smartphone, power bank, and earphones on the go.



## INTEGRATED HEADLAMP BEAM & PASSING SWITCH

Integrated smart single switch for passing signal and low/high beam.



## 3+7 YEARS WARRANTY PACKAGE

Enjoy complete peace of mind with a 10-year warranty (3 years standard + 7 years optional).



## SEAL CHAIN

The seal chain is low on maintenance and high on durability and provides a hassle-free riding experience.



# Safety

## SIDE STAND ENGINE CUT-OFF

Adds to the Safety of the rider, it cuts off the ignition if the Vehicle is put in gear when the side stand is engaged.

## WIDER REAR TYRE

SP125 comes with wider rear tyre, which gives it better traction and grip to ensure better braking.

## 5-STEP ADJUSTABLE REAR SUSPENSION

It makes your ride comfortable across all road conditions.



# Available Colours

Pearl Siren Blue



Mat Steel Black Metallic



# SP125

## Technical Specification<sup>+</sup>



### Body Dimensions

Length	2027 mm
Width	785 mm
Height	1091 mm
Wheel Base	1285 mm
Ground Clearance	160 mm
Kerb Weight	Disc - 117 kg
Seat Length	678 mm
Seat Height	790 mm
Fuel Tank Capacity	11 L



### Engine

Type	4 Stroke, SI Engine
Displacement	123.94 cc
Max Net Power	8 kW @ 7500 rpm
Max Net Torque	10.9 N-m @ 6000 rpm
Fuel System	PGM - FI
Bore X Stroke	50.0 X 63.1 mm
Compression Ratio	10.0:1
Starting Method	Self/Kick start



### Transmission

Clutch Type	Multiplate Wet Clutch
No. of Gears	5 Gears



### Tyres & Brakes

Tyre Size & Type (Front)	80/100-18M/C 47P, Tubeless
Tyre Size & Type (Rear)	100/80-18M/C 53P, Tubeless
Brake Type & Size (Front)	Disc - 240 mm
Brake Type & Size (Rear)	Drum - 130 mm



### Frames & Suspensions

Frame Type	Diamond Type
Front Suspension	Telescopic
Rear Suspension	Hydraulic Type



### Electricals

Battery	12V, 5.0Ah
Head Lamp	LED, DC

## Honda Motorcycle and Scooter India Pvt. Ltd.

Registered Office: Plot No. 1, Sector - 03, IMT Manesar, Distt. Gurugram,  
(Haryana) – 122050, India

For more details:

Visit us at: [www.honda2wheelersindia.com](http://www.honda2wheelersindia.com) | Customer Care: [customercare@honda.hmsi.in](mailto:customercare@honda.hmsi.in)

**GS Dream Honda**  
72/8, Chak Raghunath  
Prayagraj  
Tel: 9415344758  
Mob: 9565500013

Follow us at :



[honda2wheelers.in](https://www.facebook.com/honda2wheelers.in)



[honda2wheelerin](https://www.instagram.com/honda2wheelerin)



[honda2wheelersin](https://www.youtube.com/honda2wheelersin)



[honda2wheelerin](https://twitter.com/honda2wheelerin)

<sup>+</sup>The technical specifications and design of the vehicles may vary according to the requirements and conditions without any notice. Product shown in the picture may vary from the actual product available in the market. Accessories shown in the picture are not part of the standard equipment. All features and colours may not be part of all variants. \*Conditions apply